

Title:

The fire resistance performance of a single-leaf, single-acting doorset with glazing when tested in accordance with BS 476: Parts 20 and 22: 1987

WF Report No:

408272 AR1



Prepared for:

Pacific Rim Wood Ltd

Ground Floor Suite
Block B
Old Kelways
Somerton Road
Langport
Somerset
TA10 9SJ

Test date:

20th December 2018



1762

The details of the sponsor of test report WF 408272 are held on file by Warringtonfire. This report is additional to that issued as 408272 on 11/04/219 and the original report shall remain valid and is not replaced by the additional report.

Contents

	Page No
Summary of Performance	3
1 Introduction.....	4
2 Specification	4
2.1 Door leaf	4
2.2 Door perimeter gaps	4
2.3 Closer forces.....	4
3 Description of Construction (Refers to Figures 1 to 4 of the Appendix)	5
4 Test Conditions	10
5 Test results.....	11
5.1 Furnace Temperature Curve	11
5.2 Unexposed Face Temperature Curves.....	12
5.3 Leaf Distortion Data	13
5.4 Door leaf to frame gaps.....	14
5.5 Observations.....	15
5.6 Times to Failure	17
6 Limitations	18
Photographs.....	19
Appendix – figures 1 to 4.....	23

Summary of Performance

The following performance was achieved from the specimen tested. Full details of the testing and specimen construction are described in the report.

Results: Fire resistance test in accordance with BS 476: Part 20/22: 1987	Times to failure:			
	<table border="1"><thead><tr><th>Integrity</th><th>Insulation</th></tr></thead><tbody><tr><td>71 (seventy one) minutes</td><td>71 (seventy one) minutes *</td></tr></tbody></table>	Integrity	Insulation	71 (seventy one) minutes
Integrity	Insulation			
71 (seventy one) minutes	71 (seventy one) minutes *			

* Failure by virtue of integrity failure. In accordance with the clause to section 7.6.1.1 of BS 476: Part 22: 1987, the glazing has not been evaluated for insulation.

	Summary of specimens: A latched single-leaf, single-acting doorset with glazing, hung opening in towards the furnace. Leaf size : 2040mm high x 928mm wide x 54mm thick
---	--

1 Introduction

The specimen was manufactured and supplied for test by the client and delivered to Warringtonfire during December 2018.

Warringtonfire constructed a plasterboard clad timber stud supporting construction and at the request of the client installed the specimen into the wall.

2 Specification

Details of the specimen are shown in the Appendix.

2.1 Door leaf

The leaf measured 2040mm high x 928mm wide x 54mm thick. The doorset was hung to open in towards the furnace. The results of this test were obtained from a doorset fitted with a multi-point latch engaged at all points for the duration of the test.

2.2 Door perimeter gaps

The gaps between the edge of the door and frame were measured prior to test. A total of 12 readings were taken. The measurements (in mm) are given in Section 5.4 of the report.

2.3 Closer forces

Measured in accordance with FTSG Resolution No 63.

Opening force (Nm)	Closing force (Nm)
24	12

3 Description of Construction (Refers to Figures 1 to 4 of the Appendix)

Leaf - (Stated by client to be a Pacific Rim Wood Ltd. Type 660 54mm Ply faced door blank)

		Species/type	Dimensions (mm)	Density (kg/m ³)	Moisture (% w/w)	Key to figures
Stiles		Agathis or mixed tropical hardwood in two lamels*	35 wide (total) x 42 thick including a 9 x 9 tongue into the core*	610*	-	1
Top rail		Agathis or mixed tropical hardwood in three lamels*	75 wide (total) x 42 thick including a 9 x 9 tongue into the core*	610*	-	2
Bottom rail		Agathis or mixed tropical hardwood in three lamels*	35 wide (total) x 42 thick including a 9 x 9 tongue into the core*	610*	-	3
Core	Inner	Mixed tropical hardwood*	15 thick x 28 wide horizontally orientated lamels*	480*	-	4
	Outer	Parasoiathes falcatera or Albisia falcatta*	13.5 thick x 45 wide vertically orientated lamels*	180-360*	-	5
Facings		Ply*	6 thick*	-	7.4	6
Adhesive	Lippings	Urea Formaldehyde manufactured by PT. Pamolite Adhesive Industry Ref. UA - 125 *	-	-	-	-
	Facings	Polychemie Asia Pacific Permai Polyvinyl acetate Ref. PC3339*	-			
Lippings – all edges		Sapele*	11 thick	640*	8.1	7

* Stated by client, not verified by laboratory

Frame

	Species/type	Dimensions (mm)	Density (kg/m ³)	Moisture (% w/w)	Key to figures
Head and jambs	Sapele*	47 thick x 90 deep including a 32 wide x 15 high integral stop	640*	8.5	8
Stop – integral	-	-	-	-	-
Head to jamb jointing detail	Comb joint*	-	-	-	-
Frame to supporting construction fire stopping detail	Rock mineral fibre for full depth of frame capped with intumescent acrylic mastic on the exposed face	Nominally 9 - 15 wide x 10 deep (mastic size)	-	-	-
Frame to supporting construction fixing detail	4No. screws per jamb	5Ø x 100 long	-	-	-
Architrave	MDF fitted on the exposed face	45 wide x 18 high	750**	10.6	-
Threshold	Exitex MXS/15 – 67*	66 wide x 16 high	-	-	9
	Sapele*	67 thick x 90 deep	640*	7.9	10

* Stated by client, not verified by laboratory

** Nominal density, Exova BMTRADA timber database

Intumescent and sealing materials

	Make/type	Size (mm)	Location	Key to figures
Leaf – head	Sealed Tight Solutions Ltd. ST154*	15 x 4*	Fitted centrally along the head of the leaf	11
Leaf – bottom edge	Sealed Tight Solutions Ltd. ST422 drop down seal*	20 high x 13 wide (rebate size)	Fitted centrally along the bottom edge of the leaf	12
Frame reveal – head and jambs	2No. Sealed Tight Solutions Ltd. ST154*	15 x 4*	Fitted 12mm apart, 6mm from the exposed face in the frame reveal	13
	Sealed Tight Solutions Ltd. ST1009*	11 x 5*	Fitted to the upstand of the stop	14
Threshold	Sealed Tight Solutions Ltd. ST202 graphite*	20 x 2*	Fitted on top of the threshold platform 18mm from the exposed face	15
Glazing perimeter	Sealed Tight Solutions Ltd. Graphite glazing liner Ref. ST302*	30 x 2*	Fitted lining the glazing aperture	16
	Sealed Tight Solutions Ltd. ST103 GT Glazing Seal*	10 x 3*	Fitted between the glass and bead on both faces	17

* Stated by client, not verified by laboratory

Intumescent interruptions and additional hardware protection

	Make/type	Size (mm)	Location
Around hinge blade	Partially interrupted	-	Hinge blade fully interrupts 1 st seal leaving 2 nd seal continuous in frame reveal
Under hinge blades	Sealed Tight Solutions Ltd. Graphite*	1 thick	Fitted under the hinge blade on frame and leaf
Encasing the middle latch body	Sealed Tight Solutions Ltd. Solutions ST60 kit*	1 thick	Fitted to the cheeks of the centre latch body
Encasing top and bottom hook latch bodies	Sealed Tight Solutions Ltd. Solutions graphite*	110 x 30 x 1 thick	Fitted to both faces of the hook latch cases
Under lock drive strip in Eurogroove	Sealed Tight Solutions Ltd. ST10x2 Graphite*	10 x 2 thick	Fitted lining the full length of the Euro groove
Around latch keeps	Partially interrupted	-	The latch keep fully interrupt the 1 st seal leaving 11mm remaining of the 2 nd
Under latch keeps	Sealed Tight Solutions Ltd. Graphite*	20 x 1 thick	Fitted around the perimeter and under the latch keep forends

* Stated by client, not verified by laboratory

Hardware – both doorsets

	Make/type	Size (mm)	Location	Key to figures
Hinges	3No. Eurospec Certifire HIN1433	100 x 31 x 3 (hinge size)	Fitted 150mm, 940mm and 1735mm from the head of the leaf	18
Closer	Rutland TS3204 overhead type closer	220 x 59 (footprint)	Surface fitted as per the manufacturer's instructions on the exposed face	19
Latch - engaged	Winkhaus AV2-F 2069 L20/45 92/8 M2 Silver and UAP Kinetica 3 Euro cylinder	1770 x 20 x 5 (forend size) 185 x 70 x 15 (centre case size) 235 x 23 x 3 (centre keep size)	Latch nib fitted 1025mm from the bottom of the leaf	20
		113 x 45 x 16 (top and bottom latch case size) 1756x 24 (top and bottom keep size)*	Fitted 240mm and 1725mm from the bottom edge of the leaf	21
Handle	Fab and Fix Windsor solid die cast zinc*	208 x 28 (footprint)	Fitted appropriate to the centre latch	22

* Stated by client, not verified by laboratory

Glazing – both apertures

	Make/type	Size (mm)	Location	Key to figures
Glass type – both aperture	Promat Pyrobelite 12*	12 thick*	Fitted 670mm apart, 141mm from the leaf head, 217mm from the leaf edges	23
Aperture size	-	474 high x 474 wide*	-	-
Sight size	-	412 high x 412 wide	-	-
Glass size	-	466 high x 466 wide*		
Expansion allowance	-	4 all-round*	-	-
Beading	Sapele (640kg/m ³ stated density, 7.6% mc)*	40 high x 28 deep including an 8 x 10 bolection return and an 20° chamfer	Fitted around the glazing perimeter on both faces	24
Beading fixings	Galino pneumatically fired steel pins*	16G x 60 long*	Fitted 50mm from corners at 150mm centres at 35°– 40° to the face of the glass*	25

* Stated by client, not verified by laboratory

4 Test Conditions

Where areas of the test specification are ambiguous or open to interpretation the Fire Test Study Group Resolutions No's 51, 63, 70, 71, 72 and 78 have been followed (further specific details are available on request). These Resolutions provide basis of common agreements between the fire test laboratories which are members of this Group.

The ambient temperature of the test area at commencement of test was 13°C.

After the first 5 minutes of the test, the furnace pressure was maintained such that it complied with the requirements of BS 476-20:1987 clause 3.2.2 (including allowance for transient occurrences in line with clause 12 (L)) at -4.25 ± 2 Pa with respect to atmosphere, at a point 0.5m from the notional floor level, equating to 0Pa at a point 1m above the notional floor level.

The furnace was controlled to follow the temperature/time relationship specified in BS 476: Part 20: 1987 as closely as possible, using the average of nine thermocouples suitably distributed within the furnace. The temperatures recorded are shown graphically in Section 5.1.

The temperature of the unexposed face of was monitored by means of five thermocouples fixed to the surface of the door leaf and three thermocouples attached to the doorframe, one at mid height on each jamb and one centrally located on the frame head. Four additional thermocouples fixed to the glass.

The thermocouple positions are shown in Figure 4 of the appendix. The average temperature of the door leaf and maximum temperature of the doorset are shown graphically in Section 5.2.

5 Test results

The following data and observations were recorded during the test.

5.1 Furnace Temperature Curve

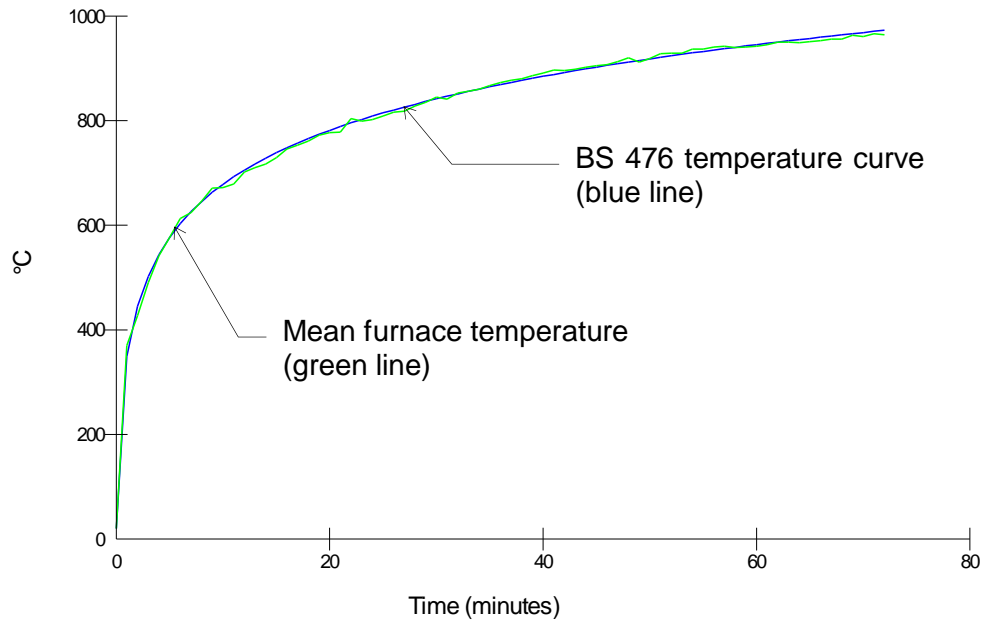

5.2 Unexposed Face Temperature Curves

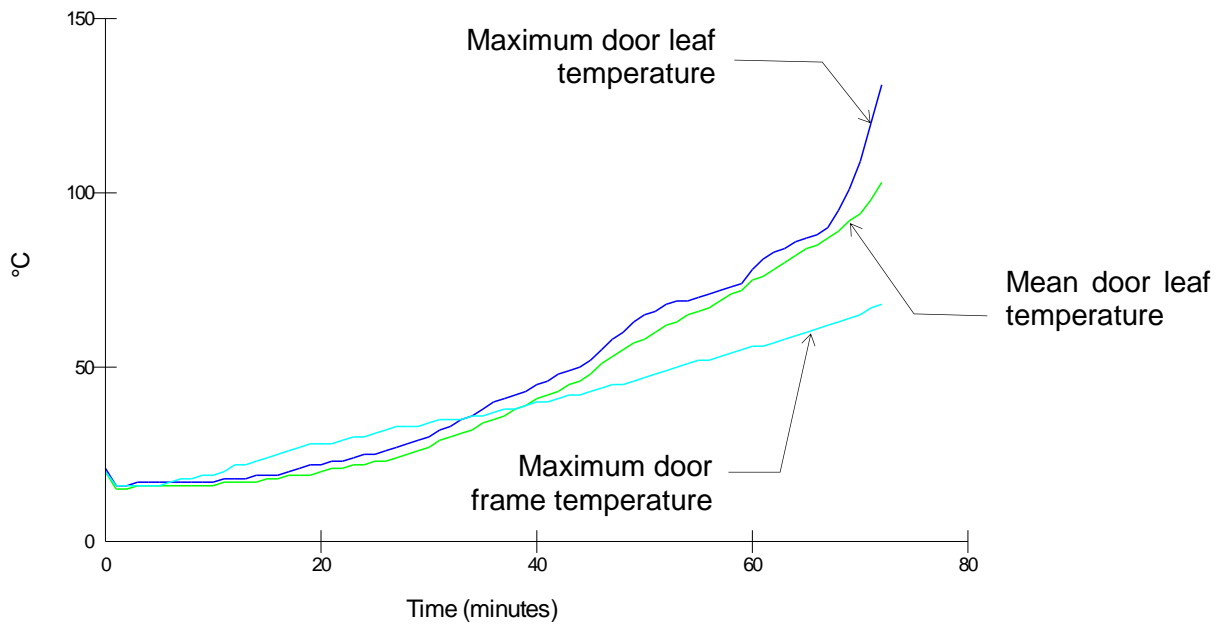

Glazing

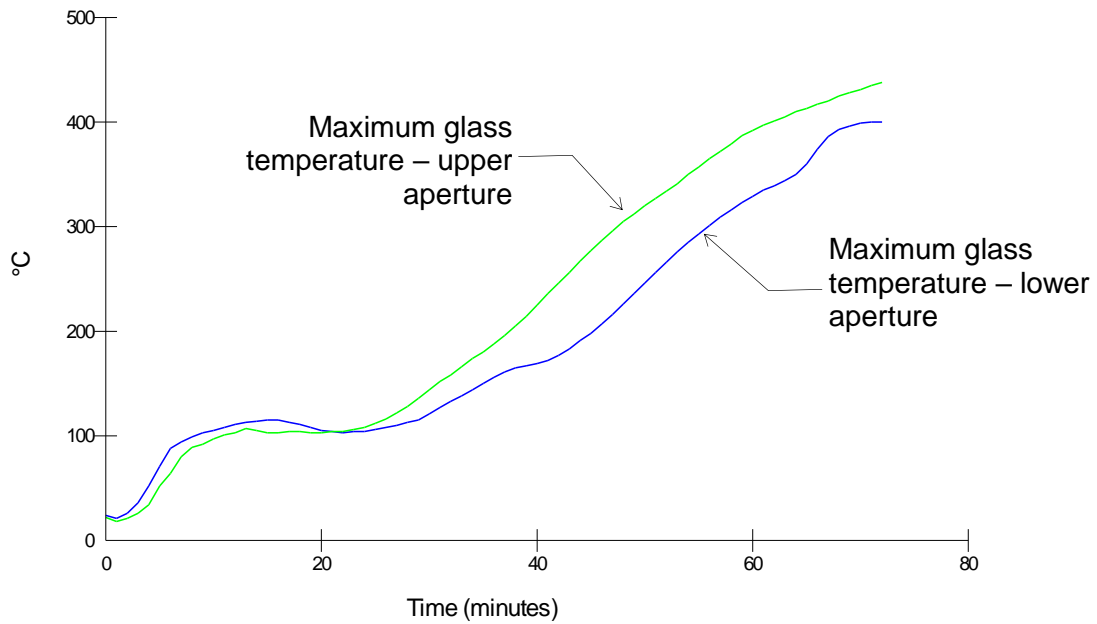

5.3 Leaf Distortion Data

The following tables show the distortion of the doors in mm with an accuracy of ± 1 mm. A positive measurement indicates distortion towards the furnace.

A negative measurement indicates distortion away from the furnace.

J, K and L give vertical movement of the door, a negative reading indicates that the door has dropped.

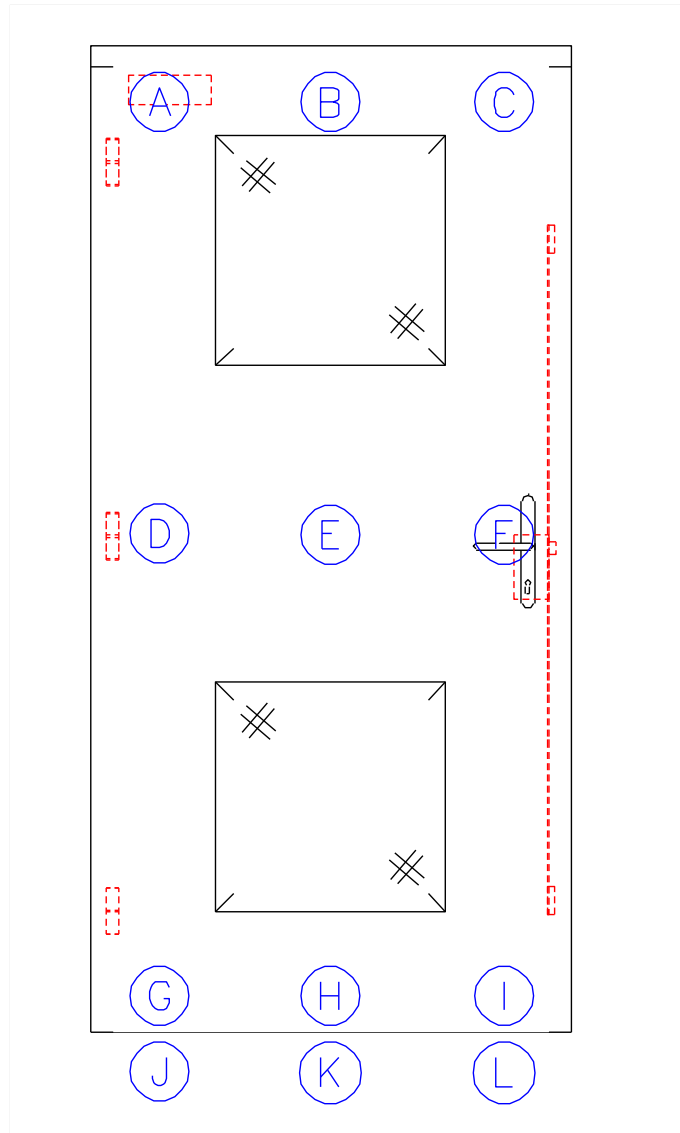

Leaf (hung on the left and opening in towards the furnace)

Time	A	B	C	D	E	F	G	H	I	J	K	L
15	1	0	-4	0	0	1	1	4	1	-1	1	-2
30	1	2	1	-1	0	1	3	3	4	-2	-2	-2
45	3	2	2	-4	-4	1	3	2	0	-2	-2	-2
60	5	2	2	-3	-2	1	5	1	0	-2	-3	-3

5.4 Door leaf to frame gaps

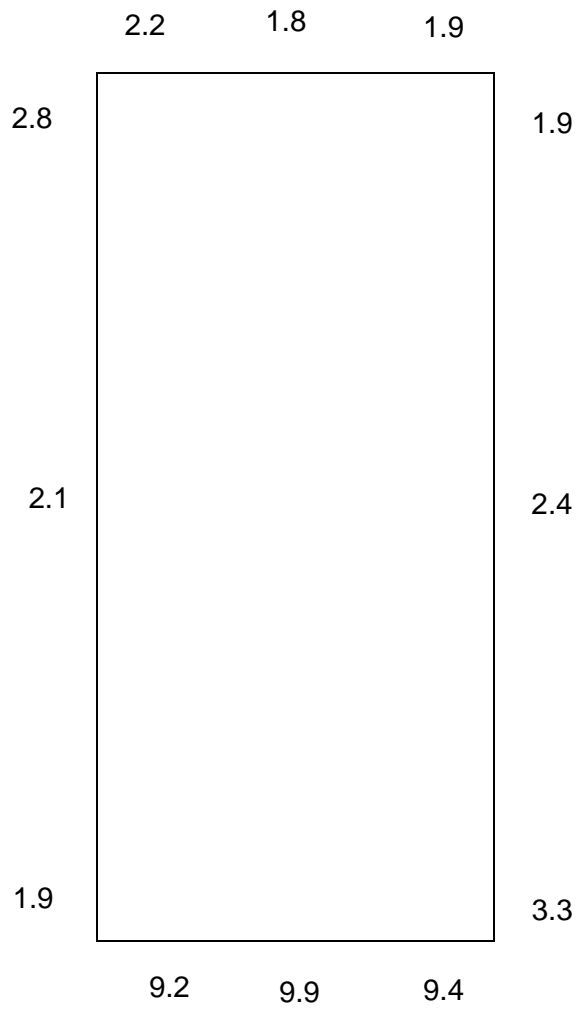

Gaps shown

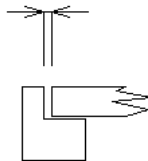

5.5 Observations

All comments relate to the unexposed face unless otherwise specified.

Time (minutes)	Comments
00:00	Test Started
02:00	There are cracks in the top and bottom glazing.
04:00	The intumescent is reacting in the glass.
05:00	There is smoke issuing from the top of the top glazing.
05:20	There is smoke issuing across the head and from the latch position.
06:00	There is smoke issuing from the middle hinge position.
07:00	There is smoke issuing from the closing edge between the top latch position and the top closing corner.
08:00	There is smoke issuing and discolouration on the cracks in the top glass.
09:30	There is smoke issuing from the top hanging corner.
11:00	There is discolouration above the top glazing.
12:00	There is smoke issuing from the closing edge approximately 300mm below the latch position.
13:00	There is discolouration at the cracks in the bottom glass.
15:40	The top glazing bead is pulling away at the top right corner.
16:30	There is discolouration at the top left corner and the top right corner of the bottom glazing bead.
17:00	There is smoke issuing from the cracks in the bottom glass.
18:00	There is an increase in smoke issuing above the top right corner of the top glazing bead.
25:00	The mastic in the fire stopping gap is melting.
32:00	There is an increase in smoke issuing from the cracks in the glazing.
34:00	The seal is falling from the frame head at the top hanging corner and the top closing corner.
38:00	There is an increase in smoke issuing from the cracks in both glass.
38:50	There is smoke issuing from the threshold.
41:00	There is an increase in smoke issuing and discolouration across the threshold.
41:20	There is an increase in smoke issuing from the latch position.

- 45:00 The graphite is oozing from the threshold.
- 51:00 There is an increase in smoke issuing from the top and bottom glazing.
- 55:00 There is an increase in smoke issuing and discolouration around the latch position.
- 58:00 There is an increase in smoke issuing from the threshold.
- 62:20 The graphite is falling from the top of the top glazing bead and left of the bottom glazing bead.
- 63:00 The acoustic seal is falling off the top of the closing edge.
- 68:20 There is a glow visible at the bottom closing corner.
- 68:50 There is a glow visible at the threshold approximately 1050mm from the bottom closing corner.
- 69:00 There is intermittent flaming at the threshold.
- 70:15 A cotton pad integrity test was performed at the threshold which did not result in the ignition of the cotton pad.
- 70:50 A cotton pad integrity test was performed at the bottom closing corner which did not result in the ignition of the cotton pad.
- 71:10 There is continuous flaming at the bottom closing corner thereby constituting **integrity failure**.
- 72:00 There is continuous flaming at the bottom glazing thereby constituting **further integrity failure**.
- Test terminated

5.6 Times to Failure

When tested in accordance with BS 476, Part 22, 1987, Method 7, determination of fire resistance of partially insulated doorsets and shutter assemblies, the requirements of the standard were satisfied for the following periods:

Integrity	Insulation
71 (seventy one) minutes	71 (seventy one) minutes *

* Failure by virtue of integrity failure. In accordance with the clause to section 7.6.1.1 of BS 476: Part 22: 1987, the glazing has not been evaluated for insulation.



6 Limitations

The results only relate to the behaviour of the element of construction under the particular conditions of test; they are not intended to be the sole criteria for assessing the potential fire performance of the element in use nor do they reflect the actual behaviour in fires.

The results of this test were obtained using the specimens provided for testing, and the door to frame gaps recorded in Section 5.4 of this report. Further, where information in relation to the specimen has been provided to us but not verified by us, we have assumed that it is correct; and where comments above identify particular materials or substances comprised in the specimen those comments are based on information supplied to us and/or on general visual inspection undertaken during the process of testing of the sample, and in either case have not been verified by reference to materials testing or documentary evidence except as described above. The fire resistance performance of doors of this design may be different if any aspect of the design or construction differs from that tested. This includes, by way of example only, any difference as a result of (i) any deviation from the information supplied to us, or (ii) the employment of different door to frame gaps. The tested assembly was asymmetrical and was tested such that the door leaf opened towards the heating conditions of the test. The test result may not be appropriate to situations where by the sample tested has been installed in a different configuration to that which it has been tested.

The specification and interpretation of fire test methods are the subject of ongoing development and refinement. Changes in associated legislation may also occur. No assurance can be given that this test or its results will reflect current practice, and/or be consistent with prevailing legislative / regulatory requirements, at any time after the date of this report. Warringtonfire will be able to offer the addressee of this report, at any time on request, a review of the procedures adopted for a particular test to ensure that they are consistent with current practices, and if required may endorse the test report. It is strongly recommended that, at the latest, such a review be sought at intervals of no more than five years.

This report may only be reproduced in full. Extracts or abridgements of reports shall not be published without permission of Warringtonfire. All work and services carried out by Warringtonfire Testing and Certification Limited are subject to, and conducted in accordance with, the Standard Terms and Conditions of Warringtonfire Testing and Certification Limited, which are available at <https://www.element.com/terms/terms-and-conditions> or upon request.

	Written and checked by:	Authorised by:
Signature:		
Name:	Courtney Clifford	Adam Scott
Title:	Technical Officer	Laboratory Manager
Date of issue:	12/04/2019	12/04/2019

Photographs

Intumescent interruption by hardware and additional intumescent protection

Around hinge blades



Intumescent in keep



Prior to the start of the test



After 15 minutes



After 33 minutes



At 45 minutes



At 60 minutes



Exposed face – post test



Appendix – figures 1 to 4



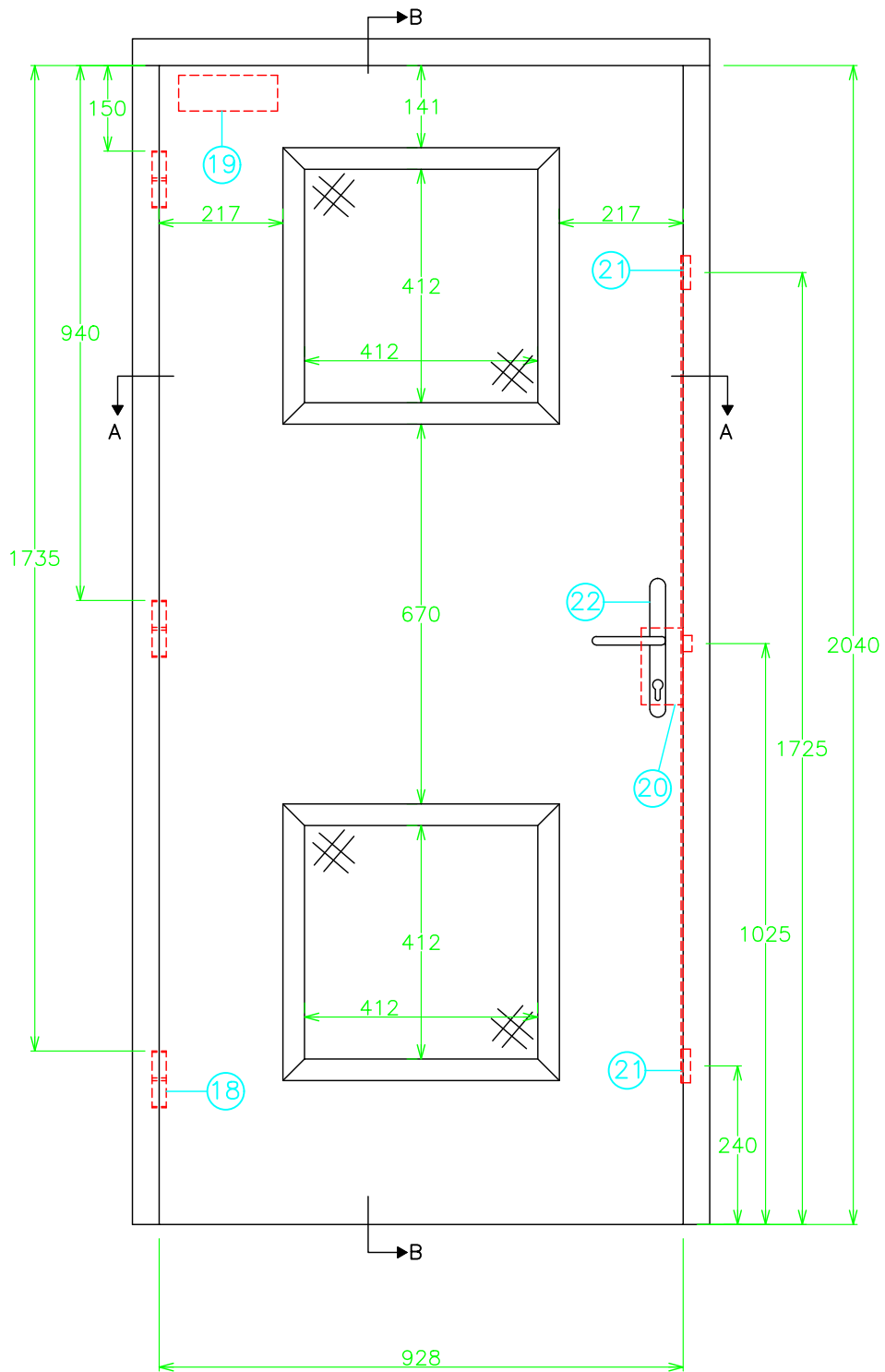

Section A-A

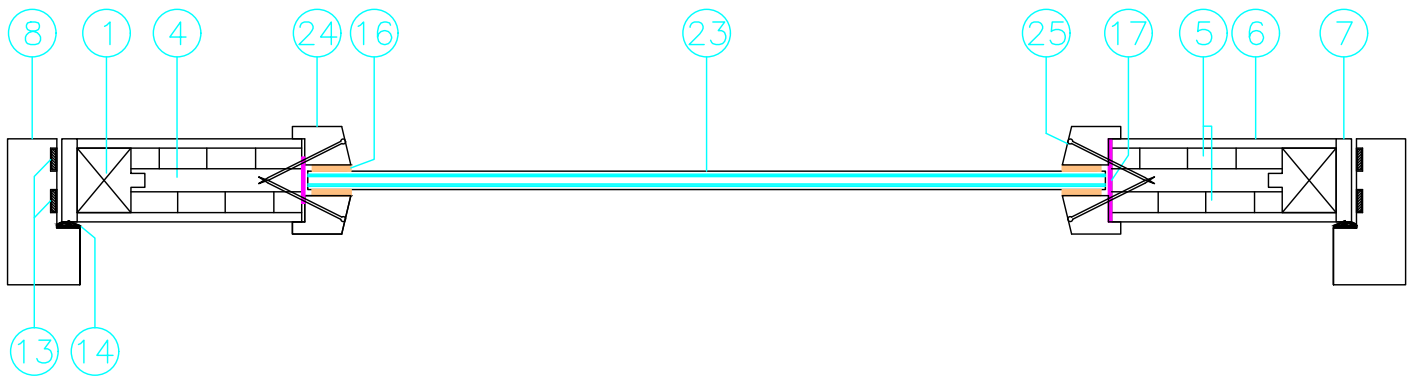

warringtonfire
 Proud to be part of 

Warringtonfire, Stocking Lane,
 Hughenden Valley, High Wycombe,
 Buckinghamshire, HP14 4ND, UK.
 Tel: +44 (0)1494 569750

Title
 Horizontal cross-sections
 (All dimensions in mm)

Date Drawn 11/01/19	Drawn By ARD	Scale NTS
------------------------	-----------------	--------------

Project No. WF 408272 AR1	Appendix
------------------------------	----------

Section B-B

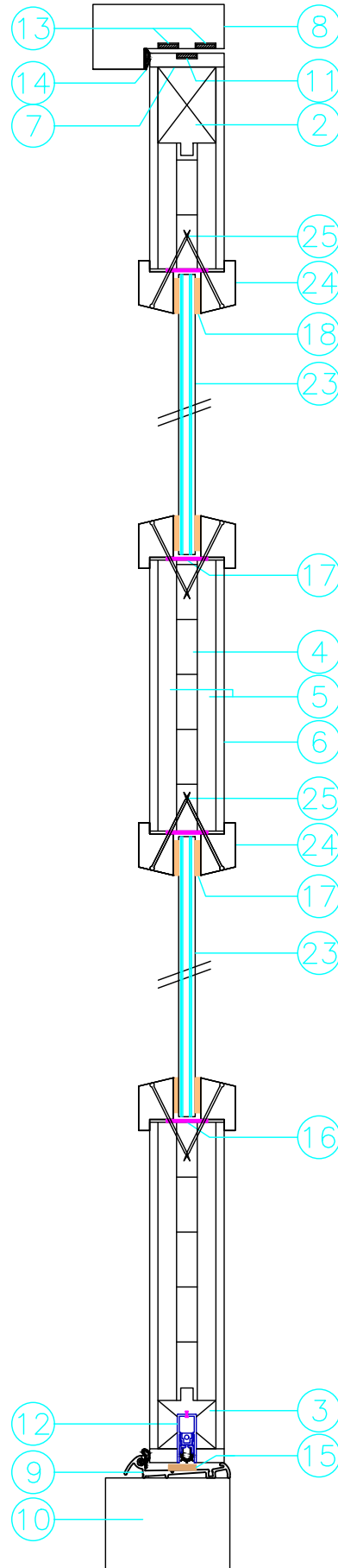

warringtonfire
Proud to be part of element

Warringtonfire, Stocking Lane,
Hughenden Valley, High Wycombe,
Buckinghamshire, HP14 4ND, UK.
Tel: +44 (0)1494 569750

Title

Vertical cross-sections
(All dimensions in mm)

Date Drawn

11/01/19

Drawn By

ARD

Scale

NTS

Project No.

WF 408272 AR1

Appendix

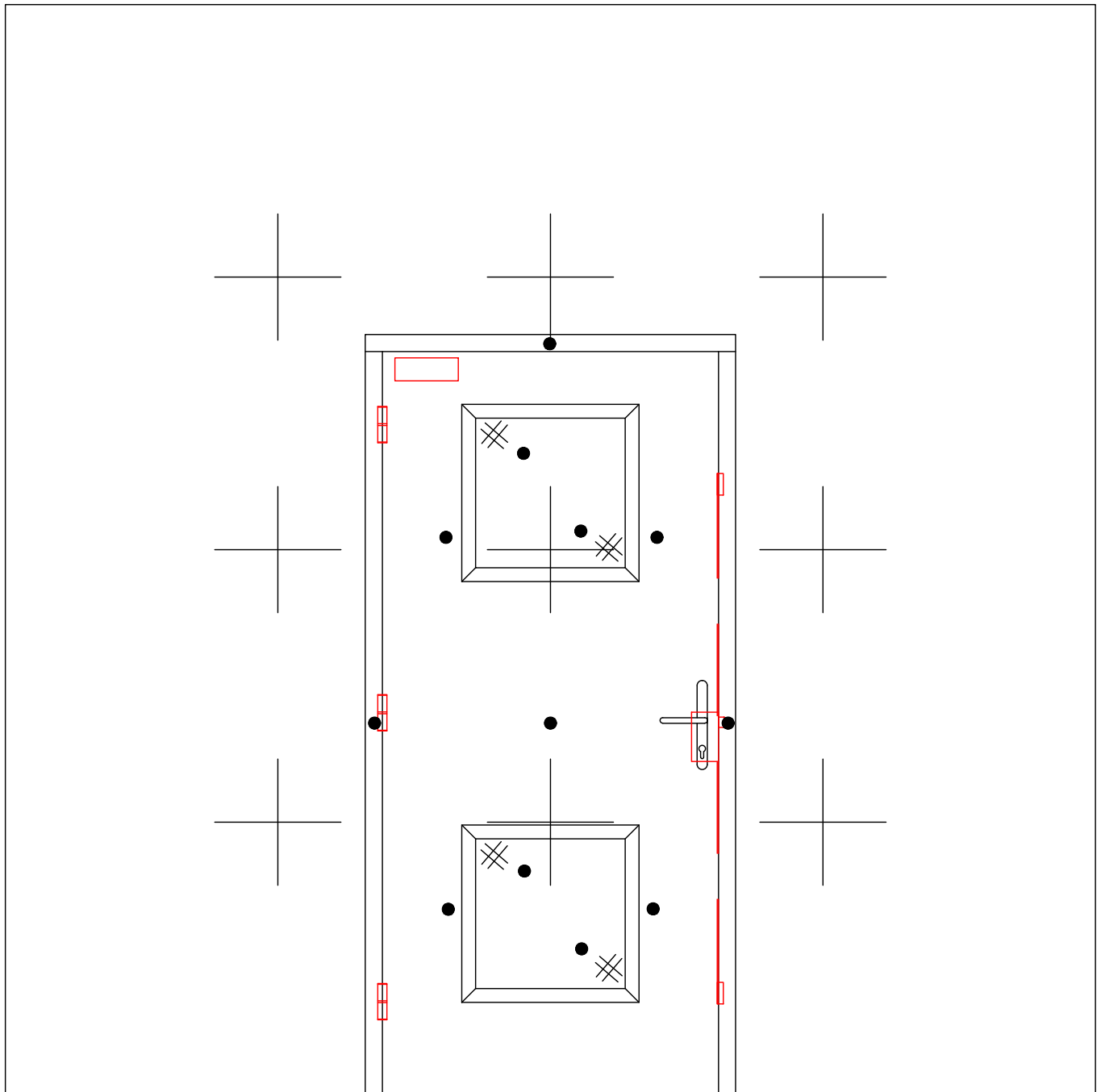

- + : Furnace Thermocouples
- : Unexposed Face Thermocouples

Viewed From Unexposed Face



Warringtonfire, Stocking Lane,
 Hughenden Valley, High Wycombe,
 Buckinghamshire, HP14 4ND, UK.
 Tel: +44 (0)1494 569750

Title Thermocouple positions

(All dimensions in mm)

Date Drawn 11/01/19	Drawn By ARD	Scale NTS
Project No. WF 408272 AR1		Appendix